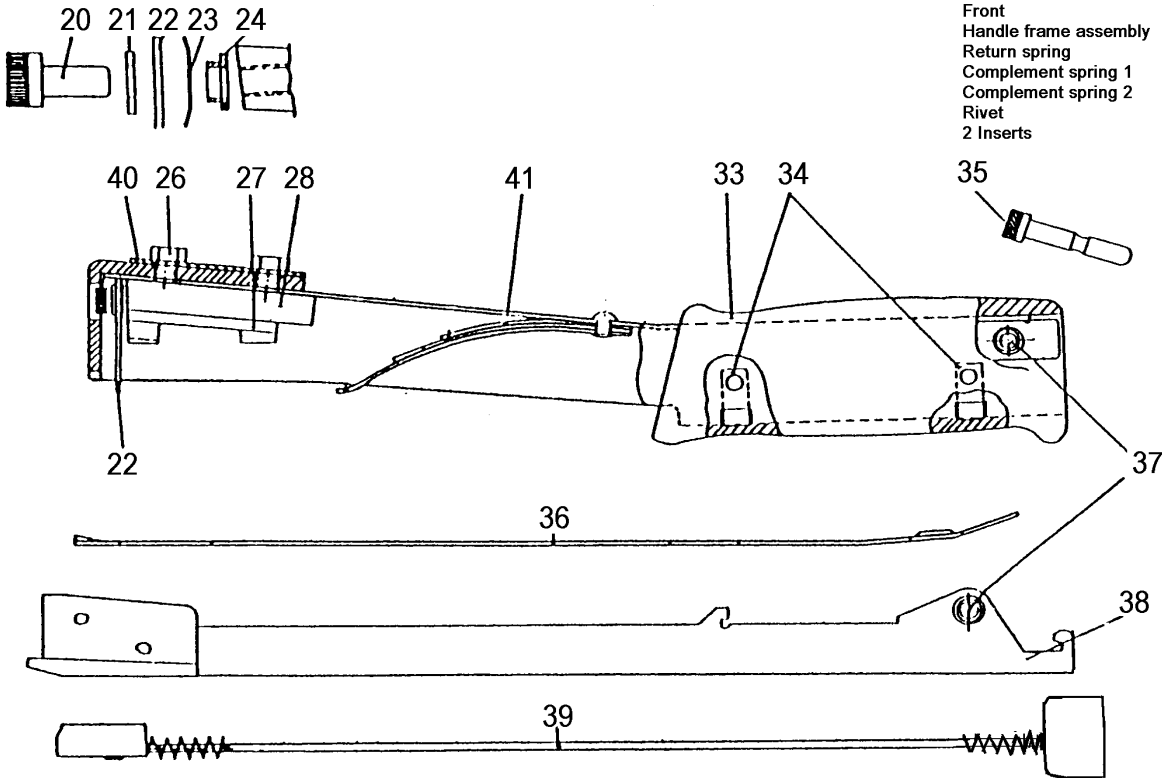

Rapid **SPARE PARTS LIST**

Reg. By kele	Appr. By peto	Appr. Date 2002-10-30	Page 1(1)	Class 053	No. 197517	Rev. 05
Info		Product name RAPID 54				

	Pos No	Part No	Part Name	Qty
 <p>* 41 includes Front Handle frame assembly Return spring Complement spring 1 Complement spring 2 Rivet 2 Inserts</p>	20	220276	Screw	1
	21	155226	Washer	1
	22	14971610	Driver	1
	23	155275	Washer spring	1
	24	149351	Spacer	1
	26	220278	Screw	2
	27	149641	Damper	1
	28	14972401	Balance block	1
	33	149328	Handle	1
	34	149658	Guide	2
	35	149815	Pin	1
	36	14958310	Lid	1
	37	149633	Bushing	4
	38	14975705	Magazine	1
	39	149922	Feeder complete	1
	40	149666	Weight	1
41 *	14969020	Handle frame assembly	1	

When ordering always state the part numbers

Head office and factory: ISABERG RAPID AB, Box 115, S-330 27 Hestra, Sweden

Telephone 46-(0)370-33 95 00. Telefax 46-(0)370-33 95 02.

Internet www.isaberg-rapid.com